



Rate-of-Rise Heat Sensor Kit (80-994) Installation Instructions

466-2241A • December 2005

Copyright © 2005, GE Security Inc.

Introduction

This is the GE *Rate-of-Rise Heat Sensor Kit (80-994) Installation Instructions*. The Rate-of-Rise Heat Sensor Kit combines a System Sensor heat detector with a learn mode wireless transmitter (UFT-ROR) in one kit. A built-in thermostat trips the transmitter when a temperature at the sensor location reaches approximately 135°F (57°C). Since many fires grow rapidly in intensity causing a rapid temperature increase, the thermostat also trips the transmitter if the temperature rises 15°F (8°C) or more, per minute.

Note: Battery life depends on how often the sensor transmits signals.

When the battery voltage gets low, the sensor transmits a low battery signal for the panel to receive. The panel then activates sirens with trouble beeps to notify the customer that the sensor battery must be replaced.

Installation guidelines

Observe the following guidelines when installing the Rate-of-Rise Heat Sensor Kit:

- Heat sensors should be installed to provide property protection. Reliance should not be placed only on heat detectors for life safety. Where life safety is involved, smoke sensors must also be installed.
- The sensors allow for normal temperature fluctuations; however, ceiling temperatures should not exceed 100°F (37°C).
- Mount the sensor in a central location in the area to be protected, either on the ceiling or on a wall.
- If mounted on a ceiling, the sensor must be at least 4 in. (10 cm) away from any walls.
- If mounted on a wall, the top of the sensor must be within 4 to 6 in. (10 to 15 cm) of the ceiling.
- The UL maximum spacing allowance for the sensor is 50 by 50 ft. (15 by 15 m). Refer to NFPA Standard 72 for application requirements.
- Do not mount the sensor close to devices that change temperature rapidly, such as ovens, heat vents, furnaces, or boilers.

Tools and supplies

You will need the following tools and supplies:

- Rate-of-Rise Heat Sensor Kit
- Phillips screwdriver
- Appropriate learn mode control panel installation instructions (for programming information)

Programming

The following steps describe the general guidelines for programming (learning) a zone. Refer to the specific installation instructions provided with the UFT-ROR and the control panel for complete programming details. The UFT-ROR must be programmed into the control panel before installation.

To program the UFT-ROR, do the following:

1. Set the panel to program mode.
2. Proceed to the *Learn Sensors* menu.
3. Select the appropriate sensor group and sensor number assignments.
4. Set the external switch in the alarm condition (closed for a normally open circuit).
5. To trip the UFT-ROR, press and release the cover tamper switch.
6. Exit program mode.

Installation

The Rate-of-Rise Heat Sensor Kit is assembled in the field. Kit components include:

- Sensor base
- Universal Fire Transmitter - ROR
- System Sensor 5601P heat detector

Mounting without an electrical box

To mount the kit without an electrical box, do the following:

1. Remove the sensor base (*Figure 1*) and mounting hardware from the packaging.

Figure 1. Sensor base

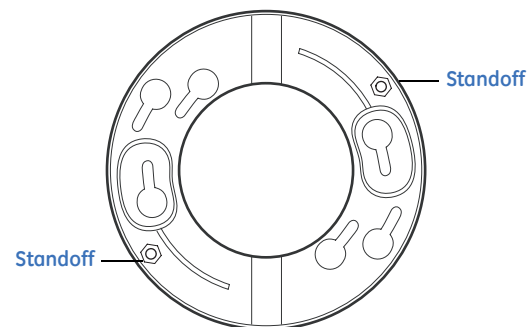

2. Determine a suitable mounting location.
3. Mark where the base will be installed using the base mounting holes as a guide.
4. Mount the base with appropriate mounting hardware.

- Remove the Universal Fire Transmitter - ROR (Figure 2) from the packaging.

Figure 2. Universal Fire Transmitter - ROR

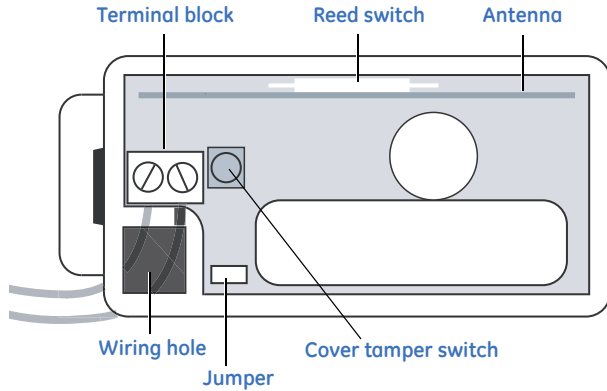

- To remove the UFT-ROR cover, squeeze the cover ends firmly to release the tab on the cover from the slot on the base.
- Connect the supplied wires to the UFT-ROR terminal block.
- Remove the System Sensor heat detector (Figure 3) from the packaging.

Figure 3. System Sensor heat detector

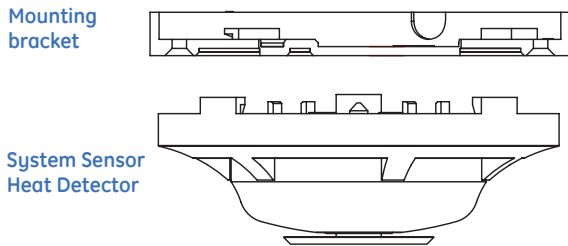

- To detach the detector from the mounting bracket, rotate the detector counter-clockwise.
- Place the UFT-ROR inside the sensor base. Place the System Sensor mounting bracket (Figure 4) onto the sensor base lining up the mounting holes labeled D with the base standoffs.

Figure 4. System Sensor mounting bracket

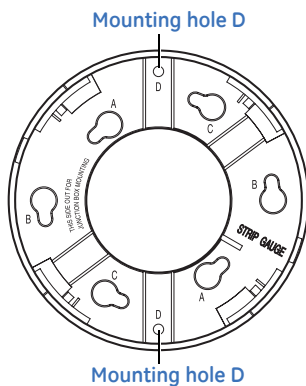

- Secure the detector mounting bracket to the sensor base using the supplied screws.
- Connect the wires from the UFT-ROR to the System Sensor heat detector terminals (Figure 5).

Figure 5. Wiring diagram

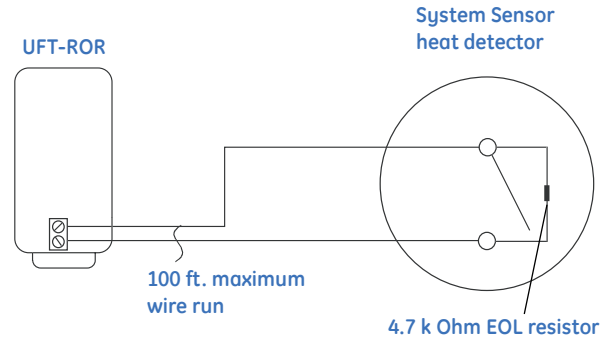

- To attach the detector to the mounting bracket, rotate the detector clockwise.

Figure 6 shows the complete kit assembly.

Figure 6. Kit assembly

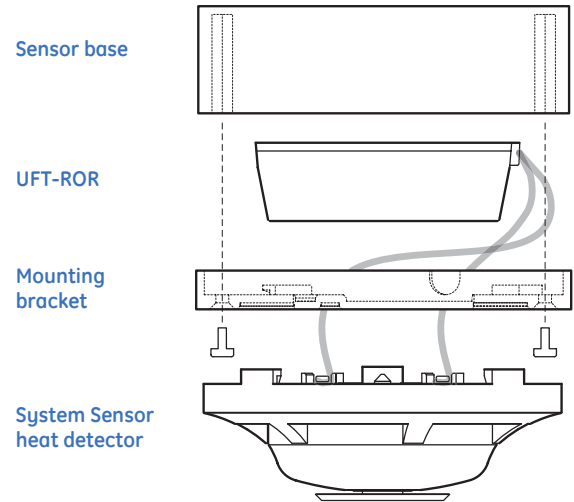

Mounting on a non-metallic electrical box

To mount the kit on a non-metallic electrical box, do the following:

1. Remove the Universal Fire Transmitter - ROR (*Figure 2* on page 2) from the packaging.
2. Connect the supplied wires to the UFT-ROR terminal block.
3. Remove the System Sensor heat detector (*Figure 3* on page 2) from the packaging.
4. To detach the detector from the mounting bracket, rotate the detector counter-clockwise.
5. Place the UFT-ROR inside the electrical box. Place the detector mounting bracket onto the electrical box while lining up the correct pair of mounting holes (*Figure 4* on page 2).
6. Secure the detector mounting bracket to the electrical box using the supplied screws.
7. Connect the wires from the UFT-ROR to the System Sensor heat detector terminals (*Figure 5* on page 2).
8. To attach the detector to the mounting bracket, rotate the detector clockwise.

Testing

Refer to the specific installation instructions provided with the System Sensor Heat Detector for complete testing details.

Before permanently securing the sensor to the wall or ceiling, test the sensor from mounting location, using one of the following methods.



CAUTION:

The test methods described only test rate-of-rise operation. These sensors cannot be field-tested for their fixed temperature ratings (135°F) without being destroyed. When used with care, the heat from a portable hair dryer (method 2) can be used for testing. Do not aim the hair dryer directly at the round disc on the sensor as this can cause it to pop off. If this happens, the sensor must be replaced.

Method 1

To test the sensor using Method 1, do the following:

1. Place the panel in the sensor test mode.
2. Rub your hands together vigorously, until they feel hot.
3. Place the palm of one hand on the round disc of the sensor for about 7 to 10 seconds.
4. Listen for the appropriate number of beeps from interior sirens and speakers (refer to the specific panel installation instructions).
5. Exit sensor test mode.

The sensor should reset in less than 1 minute.

Method 2

To test the sensor using Method 2, do the following:

1. Plug in a portable hair dryer.
2. Hold the hair dryer about 12 to 18 in. (30 to 46 cm) from the sensor, aiming it at the side of the sensor.
3. Listen for the appropriate number of beeps from interior sirens and speakers (refer to the specific panel installation instructions).
4. Exit sensor test mode.

The sensor should reset in less than 1 minute.

Technical support

Toll-free: 888.GESECURity (888.437.3287 in the US, including Alaska and Hawaii; Puerto Rico; Canada).
Outside the toll-free area: Contact your local dealer.

www.gesecurity.com